

Atmega8 DEVELOPMENT BOARD *C031*

Our ATmega8 Development Board provides a very simple and cost effective platform for prototyping solution. The compact design provides connection to all the pins of the microcontroller for the user.

- Prototyping solution available for 28-pin ATmega series AVR microcontroller from ATMEL
- All the three ports available to the user via standard 10 pin box header with supply of 5 VDC for interfacing circuits
- Onboard reset switch for easy reset of the microcontroller
- ISP (In circuit Serial Programming) connector available for chips with ISP support
- 8 MHz crystal on board
- UART level shifter circuit using MAX232 IC, on board for easy connection of the board to the RS232 devices
- Jumper selectable connection available for connecting the UART level Shifter to the port pins
- On board voltage regulator available for sourcing regulated 5V @ upto 1A voltage to the board and connecting circuit
- Power-On LED indicator
- AUX Power source of 5 VDC available on a PBT connector for sourcing DC supply to interfacing circuits
- Four mounting holes of 3.2 mm each
- PCB dimensions 60 mm x 89 mm

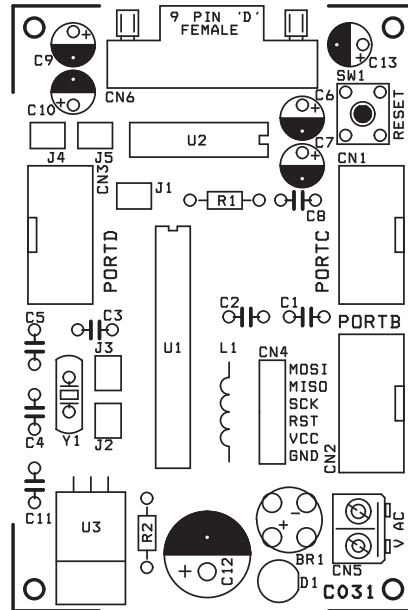
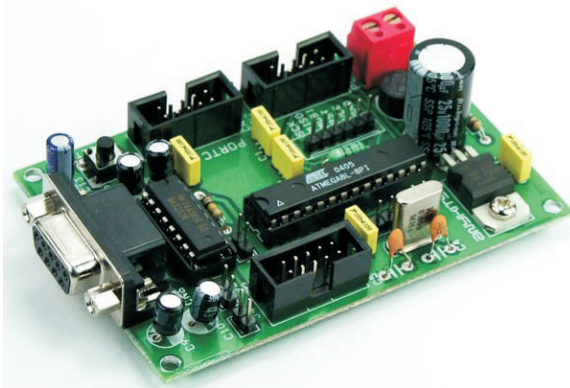

- CN5 - Power Supply 8 to 18 VDC
- CN2 - Port B
- CN1 - Port C
- CN3 - Port D
- CN4 - ISP Connector

SR.	QTY.	REF	DESCRIPTION
1	1	BR1	W04/W06/W08 BRIDGE RECTIFIER
2	3	CN1,CN2,CN3	10 PIN BOX HEADER CONNECTOR
3	1	CN4	6 PIN BERG CONNECTOR
4	1	CN5	2 PIN PBT
5	1	CN6	9 PIN D CONNECTOR - FEMALE
6	5	C1,C2,C3,C8,C11	0.1uF
7	2	C4,C5	33pF
8	4	C6,C7,C9,C10	10uF/50V OR 63V
9	1	C12	1000uF/25V
10	1	C13	100uF/25V
11	1	D1	RED LED
12	5	J1,J2,J3,J4,J5	2 PIN JUMPER
13	1	L1	100uH
14	1	R1	100K
15	1	R2	1K
16	1	SW1	TACT SWITCH
17	1	U1	ATmega8L
18	1	U2	MAX232
19	1	U3	LM7805
20	1	Y1	8MHz CRYSTAL
21	1	SOCKET	28-N PIN DIP IC SOCKET
22	1	SOCKET	16 PIN DIP IC SOCKET
23	1	SCREW	SC02905
24	1	NUT	NT02900

